

MODEL: HM-308APS

AUTOMATIC GROMMETS INSERTING MACHINE

Feature:

- Automatic dual feeding of top and bottom pieces
- With auto piercing system.

SPECIFICATION:

MOTOR: 1/4 HP

VOLTAGE: 110V 60HZ AC

THROAT DEPTH: 5"

WEIGHT: 400 LBS

PACKIN SIZE:27"X29"X67"

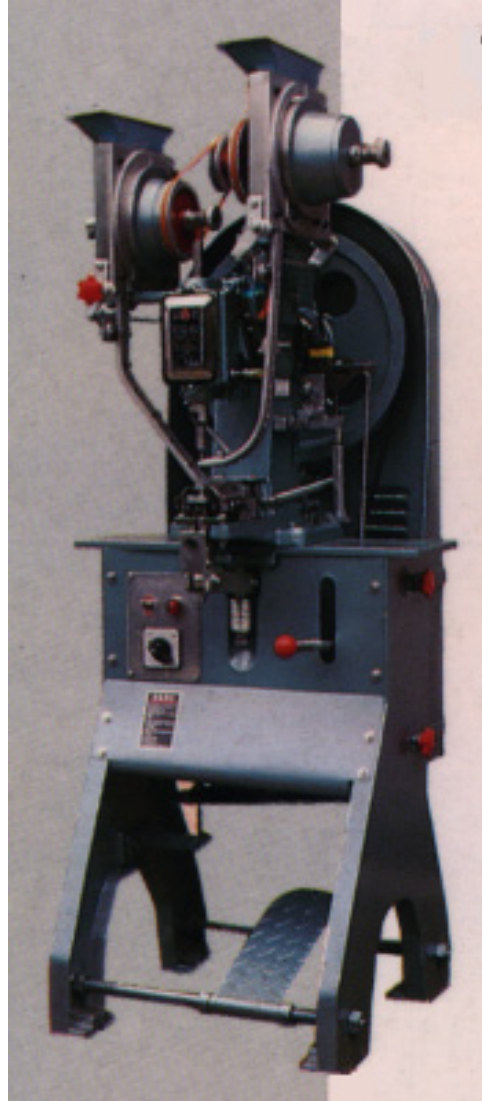

Hiker Enterprises Ltd.

3375 14th Ave. Unit #3, Markham, Ontario , Canada L3R 0H2

Phone: 905-479-5390 Fax: 905-479-0530

Email: info@hikereyelets.com Web: www.hikereyelets.com

CONTENTS

BASE SUPPORT SYSTEM EXPLODED VIEW (FIG 1).....	5
PARTS LIST (FIG 1).....	6
DIES AND DIE SEATS LINKING SYSTEM EXPLODED VIEW (FIG 2).....	7
PARTS LIST (FIG 2).....	8
DIE AND DIE SEAT SYSTEM EXPLODED VIEW (FIG 3).....	9
PART LIST (FIG 3).....	10
PUSHER SYSTEM EXPLODED VIEW (FIG 4).....	11
PARTS LIST (FIG 4).....	12
BODY, PULLEY AND MAIN SHAFT EXPLODED VIEW (FIG 5).....	13
PARTS LIST (FIG 5).....	14
SAFETY DEVICE SYSTEM EXPLODED VIEW (FIG 6).....	15
PARTS LIST (FIG 6).....	16
CLUTCH CONTROL SYSTEM EXPLODED VIEW (FIG 7).....	17
PARTS LIST (FIG 7).....	18
CLUTCH SYSTEM EXPLODED VIEW (OLD TYPE) (FIG 8).....	19
PARTS LIST (FIG 8).....	20
CLUTCH SYSTEM EXPLODED VIEW (NEW TYPE) (FIG 9).....	21
PARTS LIST (FIG 9).....	22
HEAD, COMPONENT CASE SYSTEM EXPLODED VIEW (FIG 10).....	23
PARTS LIST (FIG 10).....	24
RIGHT FEEDING SYSTEM EXPLODED VIEW (FIG 11).....	25
PARTS LIST (FIG 11).....	26
LEFT FEEDING SYSTEM EXPLODED VIEW (FIG 12).....	27
PARTS LIST (FIG 12).....	28
ASSEMBLIES REPLACEMENT (FIG 13).....	29
PARTS LIST (FIG 13).....	30
NORMAL WARNOUT PARTS LIST.....	31
WIRE DIAGRAM.....	32

THIS BOOKLET IS PUBLISHED BY HO HUNG MING ENTERPRISES CO., LTD.
TO PROVIDE OUR CUSTOMERS WITH INFORMATION TO HELP MAINTAIN THE
MACHINES AND ORDER REPLACEMENT PARTS. HO HUNG MING IS DEDICATED
TO HELP OUR CUSTOMERS ANY WAY WE CAN. SO, IF YOU HAVE ANY
INQUIRES, PLEASE DO NOT HESITATE TO ASK. THANK YOU.

GENERAL DESCRIPTION

1. DATA:

- (1) MOTOR:1/4HP
- (2) VOTAGE:110V 、 220V 、 3PH 、 50-60HZ.
- (3) SUITABLE FOR:TUBULAR RIVETS, SNAPS, PLASTIC BUTTONS, SNAP
FASTENERS, PRONGS, AND TACKS.
- (4) CAN BE USED ON:RAINCOATS, GARMENTS, STATIONERY, RUBBER ITEMS,
PLASTIC ITEMS, LEATHER BAGS.
- (5) THROAT DEPTH:5"
- (6) GROSS WEIGHT:240KG
- (7) PACKING SIZE:27"X29"X67"

2. CAUTION:

- (1) BEFORE OPERATING, YOU SHOULD CHECK THAT THE INPUT VOTAGE IS
THE SAME AS YOUR MOTOR'S.
- (2) BEFORE SWITCHING THE POWER, YOU SHOULD CHECK THE PROPER
DISTANCE BETWEEN UPPER AND LOWER DIES BY TURNING THE FLYWHEEL
ONE COMPLETE TURN WITH HAND.
- (3) DRIP THE OIL INTO THE HOLES TO LUBRICATE THE MOVING PART, AND
PUT THE GREASE INTO THE CUP.
- (4) WORNOUT PARTS MUST BE RESUPPLIED FROM OUR COMPANY AS YOU SET
TO US THE CORRECT PART NUMBERS, AS SHOWN A-15, B-03, AS SOON
AS POSSIBLE.

ORDERING REPLACEMENT PARTS

ALL PARTS OF THIS MACHINE HAVE BEEN ASSIGNED PARTS NUMBER IN THE CATALOG BOOK. THESE PARTS ARE SHOWN IN THE EXPLDED VIEW DRAWINGS.

WHEN ORDERING ANY PARTS, THE FOLLOWING INFORMATION MUST BE SUPPLIED:

- A. YOUR COMPANY'S NAME AND ADDRESS.
- B. MACHINE MODEL AND SERIAL NUMBER. LOCATED ON NAME PLATE OF MACHINE.
- C. THE STYLE AND CARD NUMBER OF THE FASTENERS BEING USED.
- D. WRITE DOWN FIG. NO., ITEM NO. AND PART NO. NAME OF PART DESIRED, UNIT AND QUANTITY. THOSE OF WHICH ARE SHOWN IN THE CATALOG BOOK.
- E. IF POSSIBLE, RETURN WORN OR BROKEN PART WITH YOUR PURCHASE ORDER WHEN YOU ARE NOT SURE.



BASE SUPPORT SYSTEM EXPLODED VIEW

(FIG. 1)





圖1 零件表

件號 ITEM NO.	名 稱 Description	數量 Qty	備 註 Remarks
A-01	馬達皮帶輪MOTOR PULLEY	1	
A-02	固定螺絲SETSCREW, MOTOR PULLEY	1	5/16"×3/4"ℓ
A-03	馬達MOTOR	1	
A-04	螺帽NUT	4	
A-05	螺帽NUT	2	
A-06	馬達底板MOTOR BEARER	1	
A-07	馬達避震膠墊RUBBER WASHER	8	
A-08	調位螺絲BEARER SUPPORTING ROD	1	
A-09	螺帽NUT	2	
A-10	馬達吊架HOLDER, BEARER SUPPORTING ROD	1	
A-11	固定螺絲FIXED SCREW	2	3/8"×3/4"ℓ
A-12	馬達固定螺絲FIXED SCREW, MOTOR	4	5/16"×1 1/2"ℓ
A-13	固定螺絲FIXED SCREW	4	3/8"×1"ℓ
A-14	固定螺絲SCREW, MOTOR BEARER SUPPORTING ROD	1	
A-15	馬達底板梢(心軸) PIN, MOTOR BEARER	1	
A-16	固定螺絲FIXED SCREW	2	3/8"×1/2"ℓ
A-17	馬達吊臂PIN HOLDER, MOTOR BEARER	1	
A-18	右底座架BASE SUPPORT, RIGHT	1	
A-19	螺帽NUT	8	
A-20	踏板固定套STOP RING PEDAL	2	3/4"×1 1/4" φ 16'
A-21	踏板PEDAL	1	
A-22	雙頭牙螺絲CROSS BAR, BASE SUPPORT	2	
A-23	固定螺絲FIXED SCREW	6	1/4"×1/2"ℓ
A-24	固定螺絲FIXED SCREW	4	3/16"×1/2"ℓ
A-25	總開關板POWER SWITCH PLATE	1	
A-26	前機蓋FRONT PANEL	1	
A-27	上拉勾UPPER TREADLE ROD	1	
A-28	固定螺絲FIXED SCREW	2	5/16"×1/2"ℓ
A-29	踏板桿接頭CONNECTOR, LOWER AND UPPER PEDAL ROD	1	
A-30	飛輪蓋(後機蓋) FLYWHEEL COVER	1	
A-31	下拉桿LOWER TREADLE ROD	1	
A-32	飛輪蓋固定板LOCK PLATE, FLYWHEEL	2	
A-33	電源插頭POWER PLUG	1	
A-34	後扭HINGE, FLYWHEEL COVER	2	
A-35	固定螺絲FIXED SCREWS	6	1/4"×1/2"ℓ
A-36	固定螺絲FIXED SCREWS	2	
A-37	固定螺絲FIXED SCREWS	2	

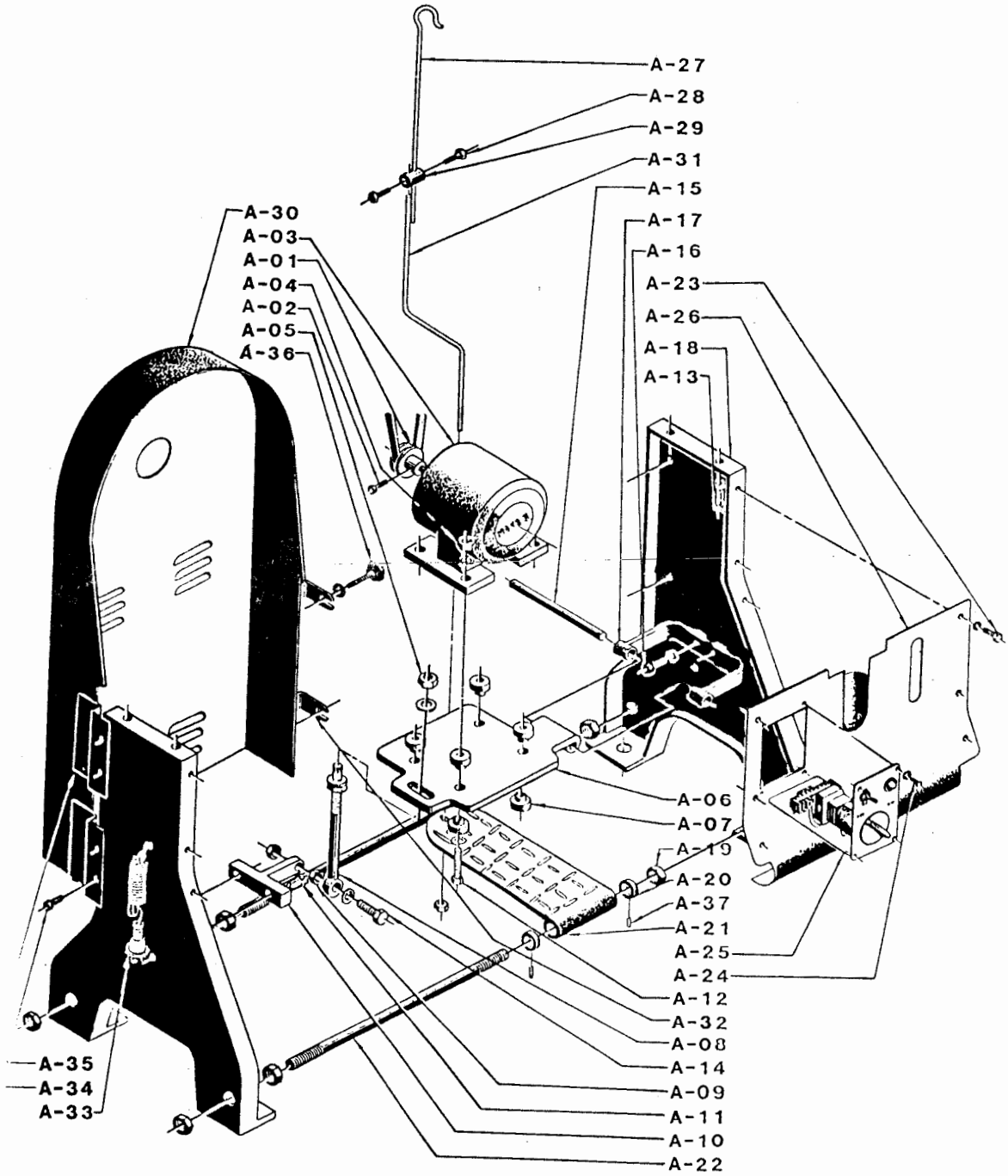

DIES AND DIE SEATS LINKING SYSTEM EXPLODED VIEW (FIG. 2)

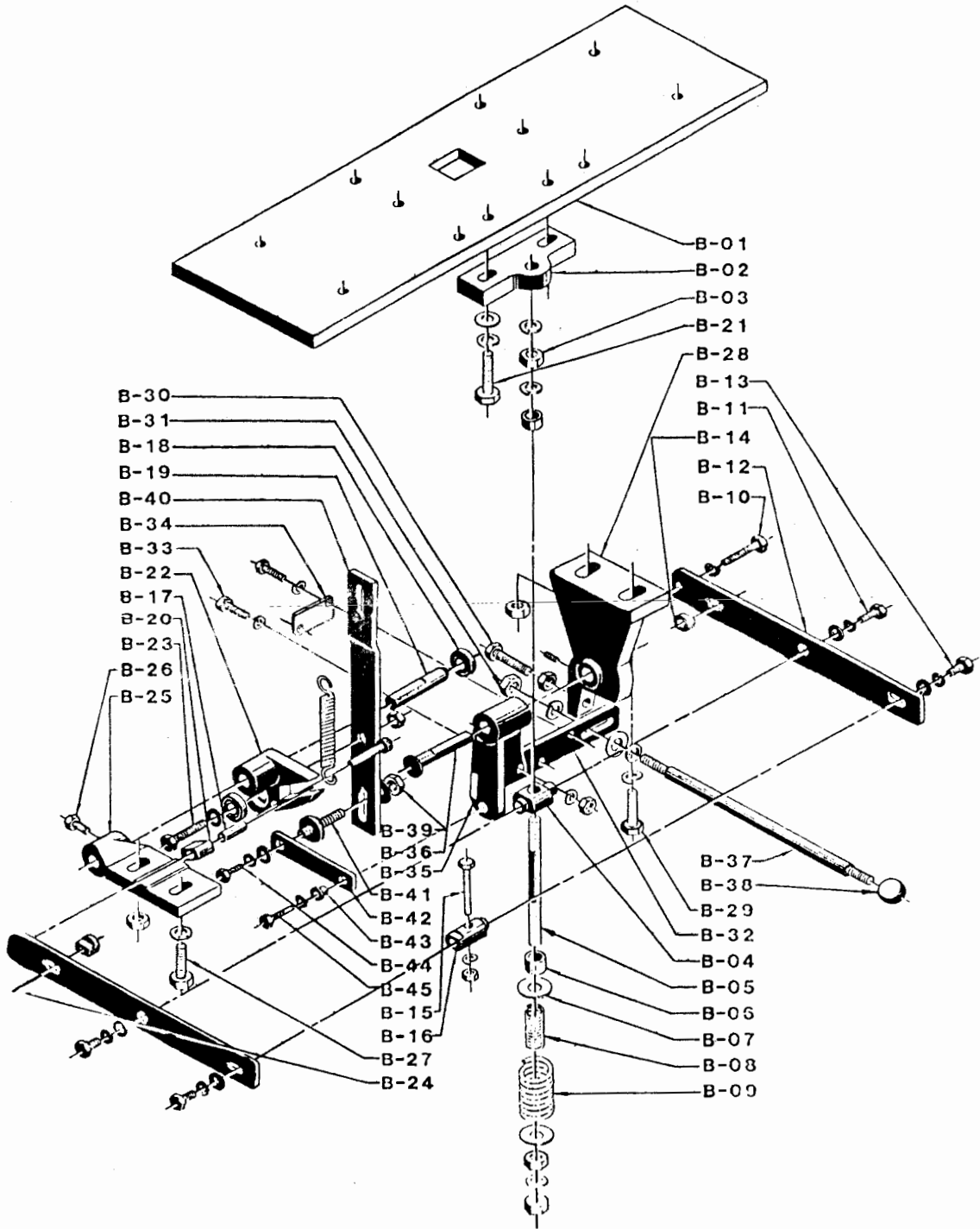

件號 ITEM NO.	名 稱 Description	數量 Qty	備 註 Remarks
B-01	平板WORK BENCH	1	
B-02	支架TAPPET STOP PLATE	1	
B-03	螺帽NUT	3	
B-04	支力活動頭JOINT, FULCRUM ROD	1	
B-05	雙頭牙螺絲FULCRUM ROD	1	1/2"×140L
B-06	套環COLLAR, FULCRUM ROD	1	
B-07	平墊圈FLAT WASHER	3	
B-08	支力桿輔助彈簧AUXILIARY COIL SPRING	1	4.6"×8"×70.4L×9圈
B-09	支力桿主力彈簧MAIN COIL SPRING, FULCRUM ROD	1	6"×11"×67L×7圈
B-10	螺絲TAPPET ARM SCREW	1	
B-11	螺絲SCREW	2	
B-12	模軸頂桿臂TAPPET ARM	2	
B-13	螺絲SCREW	2	1/4"×1 1/2" L
B-14	軸襯 (眼套) BUSHING-SHAFT	2	
B-15	頂下模螺絲TAPPET ADJUSTING SCREW	1	3/8"×2" L
B-16	調位套TAPPET ADJUSTER	1	
B-17	套管軸襯BUSHING-SHAFT PIPE	1	
B-18	軸承BEARING	2	6000#, 26"×10"×8"
B-19	心軸SHAFT PIN, OSCILLATING HEAD	1	5/8"
B-20	擺頭銅仁SLIDING KEY, OSCILLATING HEAD	1	
B-21	固定螺絲FIXED SCREW	2	3/8"×1 1/2" L
B-22	擺動叉OSCILLATING HEAD	1	
B-23	螺絲SCREW	1	5/16"×1 1/4" L
B-24	搖臂梢ROCKER ARM PIN	1	5/16"×50L
B-25	吊架板HANGING BRACKET	1	
B-26	固定螺絲FIXED SCREW	1	5/16"×3/4" L
B-27	固定螺絲FIXED SCREW	2	
B-28	手把主架座 (支架) LINK PUSHING BRACKET	1	
B-29	固定螺絲FIXED SCREW	1	
B-30	推動板調整螺絲ADJUSTING SCREW, PUSHING PLATE	1	5/16"×2" L
B-31	螺帽NUT	1	
B-32	擺頭接片PUSHING PLATE	1	
B-33	固定螺絲FIXED SCREW	1	3/8"×1 1/4" L
B-34	墊片WASHER	1	50×30×1/8"
B-35	手把主架 (擺頭) PUSHER LINK PIECE	1	
B-36	手把心軸 (擺頭支持軸) PUSHER SHAFT	1	
B-37	手把主桿HAND PUSHING ROD	1	
B-38	手把塑膠球KNOB, HAND PUSHING ROD	1	
B-39	螺帽NUT	1	
B-40	搖臂ROCKER ARM	1	
B-41	調位軸ADJUSTING SHAFT	1	
B-42	連接板CONNECTING PLATE	1	
B-43	運動片襯套 (眼套) BUSHING-SHAFT, CONNECTING PLATE	1	
B-44	螺絲SCREW	1	1/4"×1/2" L
B-45	螺絲SCREW	1	5/16"×1 1/4" L



DIE AND DIE SEAT SYSTEM EXPLODED
VIEW (FIG. 3)





圖3 零件表

件號 ITEM NO.	名 稱 Description	數量 Qty	備 註 Remarks
C-01	下模 LOWER DIE (SIZES CAN BE CHANGED)	1	可依鈕釦不同更換
C-02	頂下模彈簧 SPRING FOR LOWER DIE	1	1°×66ℓ×3.5°×19
C-03	下模軸套 LOW DIE SOCKET	1	
C-04	下模軸固定螺絲 LOW DIE FIX SCREW	1	1/4"°×3/4"ℓ
C-05	模底固定螺絲 BASE FIXING SCREW	2	5/16"°×2"ℓ
C-06	台底固定螺絲 SCREW	4	3/8"°×3"ℓ
C-07	下模座 LOW DIE BASE	1	
C-08	彈簧圈 SPRING	1	3°×37°×60ℓ×14°×5
C-09	軸墊 SEAT	1	
C-10	擋片 SIDE PLATE	1	
C-11	平墊圈 FLAT WASHER	1	
C-12	固定擋板螺絲 SOCKET HEAD SCREW, SIDE PLATE	1	5/16"°×3/4"
C-13	螺帽 NUT	2	

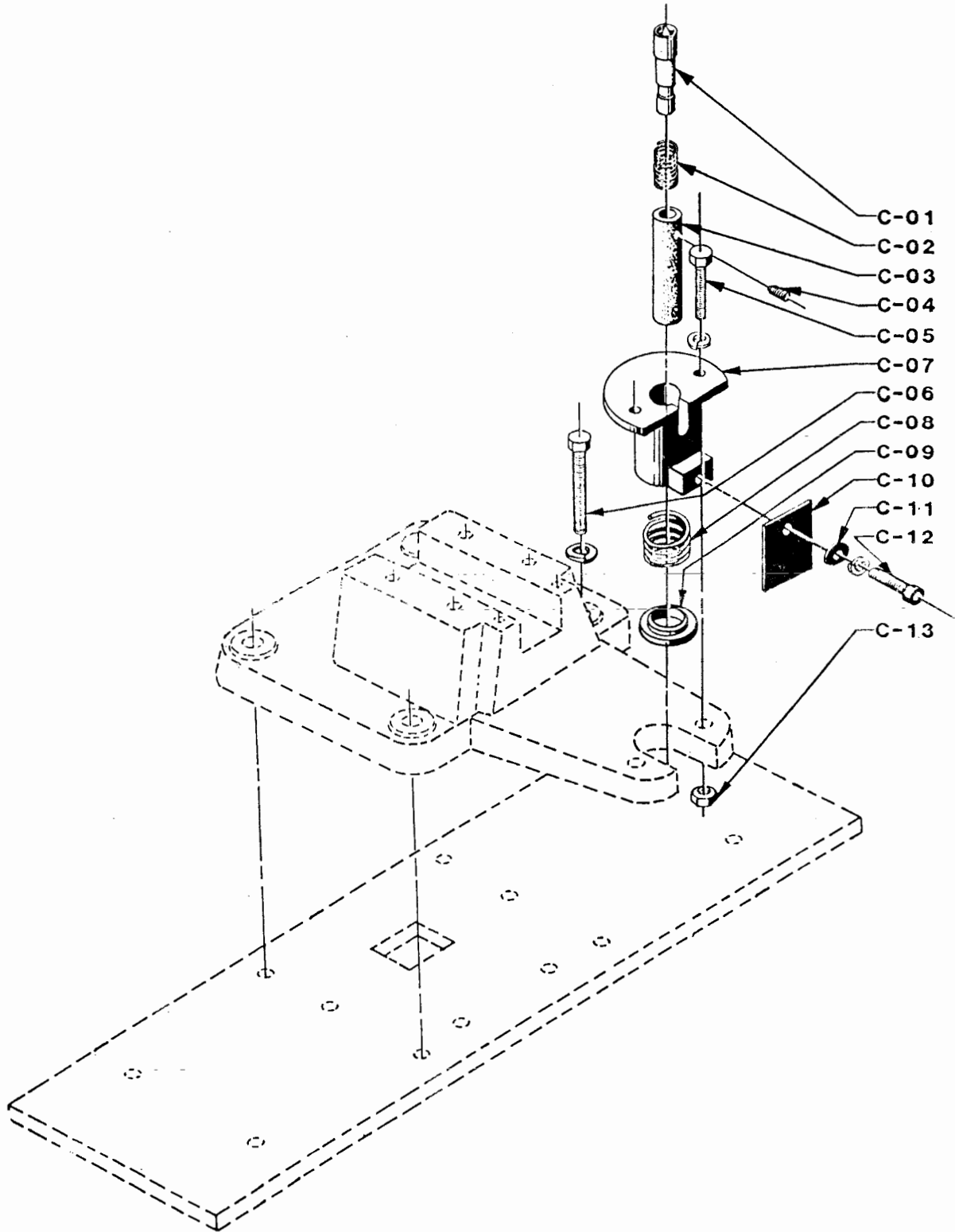

PUSHER SYSTEM EXPLODED VIEW

(FIG. 4)





圖4 零件表

件號 ITEM NO.	名 稱 Description	數量 Qty	備 註 Remarks
D-01	螺絲FIXED SCREW	4	3/16"×1 1/4"ℓ
D-02	推釘桿PUSH ROD	1	
D-03	右墊邊GUIDE BLOCK	1	
D-04	控制片CONTROL GUIDE FEEDINGS	1	
D-05	控制片簧SPRING LEAF, CONTROL	1	
D-06	墊圈WASHER	1	
D-07	控制片簧固定螺絲SPRING LEAF SCREW	1	3/16"×1/4"ℓ
D-08	左後墊邊SQUARE BLOCK, SIDE	1	
D-09	墊塊GUIDE BLOCK	1	
D-10	左前墊邊GUIDE BLOCK	1	
D-11	推槽GUIDE-WAYS SEAT	1	
D-12	推槽底座(銑台)PUSH BASE	1	
D-13	下夾支持梢JAW PIN	2	5"×45ℓ
D-14	下夾頭JAWS	1	
D-15	眼鏡彈簧 SPRING JAWS	1	
D-16	右安內JAW COVER	1	
D-17	固定螺絲SCREWS	2	1/4"×1/2"ℓ
D-18	左安內JAW COVER	1	
D-19	固定槽座鍵SLOT KEY, GUIDE	1	
D-20	圓套SLEEVE, SLIDING ARM	2	3/4"×8"×1/2"
D-21	固定螺絲SCREWS	2	1/4"×1/2"ℓ
D-22	後推條SLIDING ARM	2	
D-23	調位套ADJUSTER	1	
D-24	圓梢PUSHING ROD PIN	1	
D-25	四角仁PUSHING ROD BLOCK	1	
D-26	圓梢PIN	1	
D-27	推釘桿梢子座螺紋梢釘THREADED PIN	1	5"×24ℓ
D-28	雙頭牙傳力桿SLIDING ARM PIN	1	
D-29	螺帽NUT	2	5/16"×6"
D-30	固定螺絲FIXED SCREW	2	1/4"×1/2"ℓ
D-31	蓋板PROTECTIVE PLATE	1	
D-32	台底BASE	1	
D-33	後推條拉簧SPRING, SLIDING ARM	2	1.2"×146ℓ×1.2"×119
D-34	後推條拉簧固定螺絲SCREW, SLIDING ARM SPRING	2	5/16"×1 1/2"ℓ
D-35	本台固定螺絲BOLT	4	3/8"×1 1/2"
D-36	槽鍵座固定螺絲SOCKET SCREW	2	3/8"×1 1/4"
D-37	墊片SPACE WASHER	1	

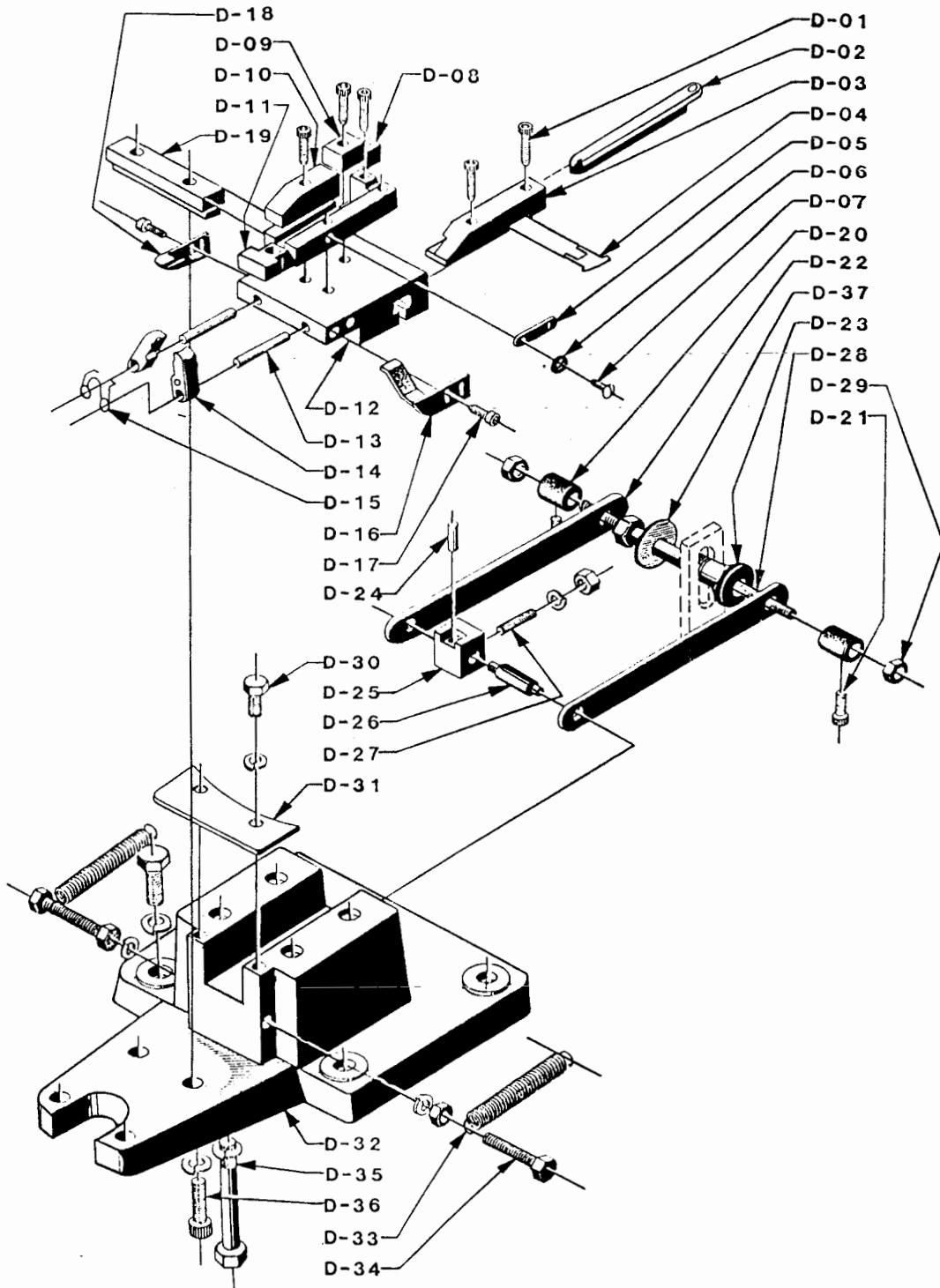

BODY, PULLEY AND MAIN SHAFT EXPLODED VIEW (FIG. 5)

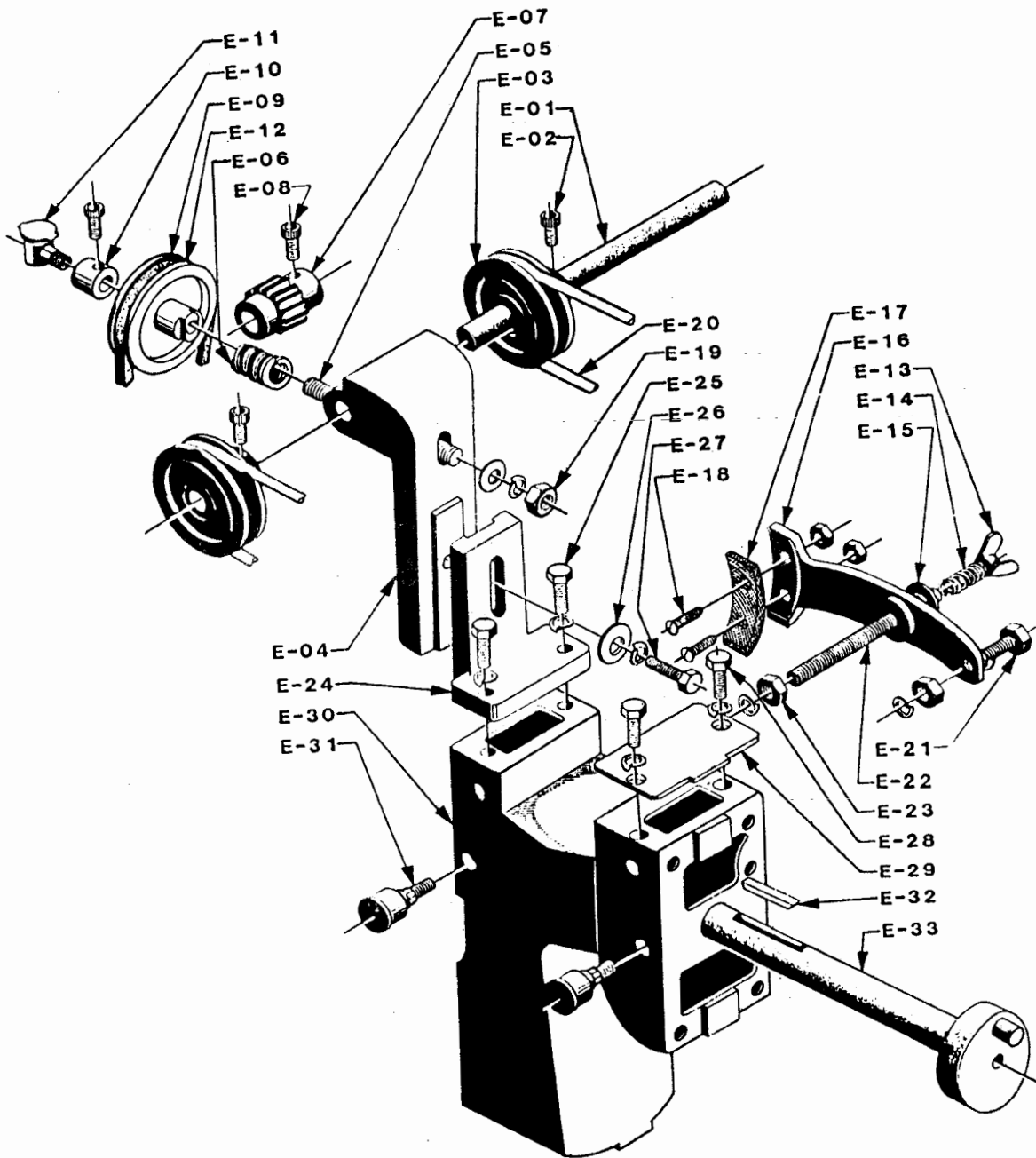

件號 ITEM NO.	名 稱 Description	數量 Qty	備 註 Remarks
E-01	漏斗帶動心軸PULLEY SHAFT	1	5/8"×200ℓ
D-02	皮帶滑輪固定螺絲SOCKET CAP SCREW, PULLEY	2	5/16"×3/4"ℓ
E-03	皮帶滑輪PULLEY	2	
E-04	滑輪架PULLEY STAND	1	
E-05	心軸WORM GEAR SHAFT	1	
E-06	蝸輪WORM GEAR	1	
E-07	蝸齒輪BUSHING-SHAFT GEAR	1	
E-08	固定螺絲SOCKET CAP SCREW, BUSHING SHAFT	1	5/16"×5/16"
E-09	皮帶輪PULLEY, WORM GEAR SHAFT	1	
E-10	固定環套OUTER COLLAR, WORM GEAR SHAFT	1	
E-11	機油杯OIL CUP	1	市購
E-12	皮帶PULLEY BELT	1	
E-13	蝶形螺母THUMB-NUT	1	3/8"
E-14	剎車彈簧COIL SPRING	1	2.3 ^d ×15 ^d ×6 ^p ×43.3ℓ
E-15	平墊圈FLAT WASHER	1	3/8"
E-16	剎車體BRAKE ANCHOR	1	
E-17	剎車來令片BRAKE LINING	1	
E-18	來令片固定螺絲SCREW, BRAKE LINING	2	3/16"×1"ℓ
E-19	螺帽NUT, WORM GEAR SHAFT	1	
E-20	圓皮帶PULLEY BELT	1	
E-21	剎車體固定螺絲SCREW, BRAKE ANCHOR	1	1/4"×1 1/2"ℓ
E-22	剎車調整螺絲THREADED STUD, BRAKE ANCHOR	1	3/8"×4"ℓ
E-23	螺帽NUT, THREADED PIN	1	3/8"
E-24	固定支架SUPPORTING STAND	1	
E-25	固定螺絲FIXED SCREW	2	5/16"×1"ℓ
E-26	平面墊圈FLAT WASHER	1	
E-27	固定螺絲SCREW, SUPPORTING STAND	1	3/8"×1 3/4"ℓ
E-28	固定螺絲SCREW, HEAD COVER PLATE	2	5/16"×1/2"ℓ
E-29	本台蓋板COVER PLATE, HEAD	1	
E-30	本台體HEAD BODY	1	
E-31	黃油杯GREASE CUP	2	
E-32	傳動主軸鍵KEY, DRIVE SHAFT	1	
E-33	傳動主軸DRIVE SHAFT	1	



SAFETY DEVICE SYSTEM EXPLODED VIEW

(FIG. 6)





圖6 零件表

件號 ITEM NO.	名稱 Description	數量 Qty	備註 Remarks
F-01	本台MACHINE BODY	1	
F-02	心軸SPINDLE	1	
F-03	吊臂HANGER ARM	1	
F-04	轆輪ROLLER	1	
F-05	安全控制臂SAFETY CONTROL BAR	1	
F-06	圓套COLLAR	1	
F-07	控制罩支持COVER SUPPORT	1	右
F-08	安全罩SAFETY COVER	1	
F-09	控制罩支持COVER SUPPORT	1	
F-10	連動擺板LINKAGE SWING ARM	1	
F-11	連動頂板LINKAGE PLATE	1	
F-12	特殊螺絲SPECIAL SCREW	1	3/8"-16UNC×40 \varnothing
F-13	六角承窩螺栓HEX SOCKET BOLT	2	5/16"-18UNC×3/4 \varnothing
F-14	六角承窩螺栓HEX SOCKET BOLT	4	1/4"-20UNC×5/8 \varnothing
F-15	彈簧墊圈SPRING WASHER	4	1/4"
F-16	彈簧COIL SPRING	2	9.5 \varnothing ×1 \varnothing ×45 \varnothing
F-17	彈簧墊圈SPRING WASHER	1	3/8"
F-18	六角頭螺栓HEX-HEAD BOLT	1	3/8"-16UNC×1 1/2 \varnothing
F-19	六角承窩螺栓HEX-SOCKET BOLT	1	5/16"-18UNC×5/8 \varnothing
F-20	六角承窩螺栓HEX-SOCKET BOLT	1	3/16"-24UNC×1 \varnothing
F-21	六角承窩螺栓HEX-SOCKET BOLT	1	1/4"-20UNC×1 \varnothing
F-22	特殊螺絲SPECIAL SCREW	1	5/16"-18UNC×1 3/4 \varnothing

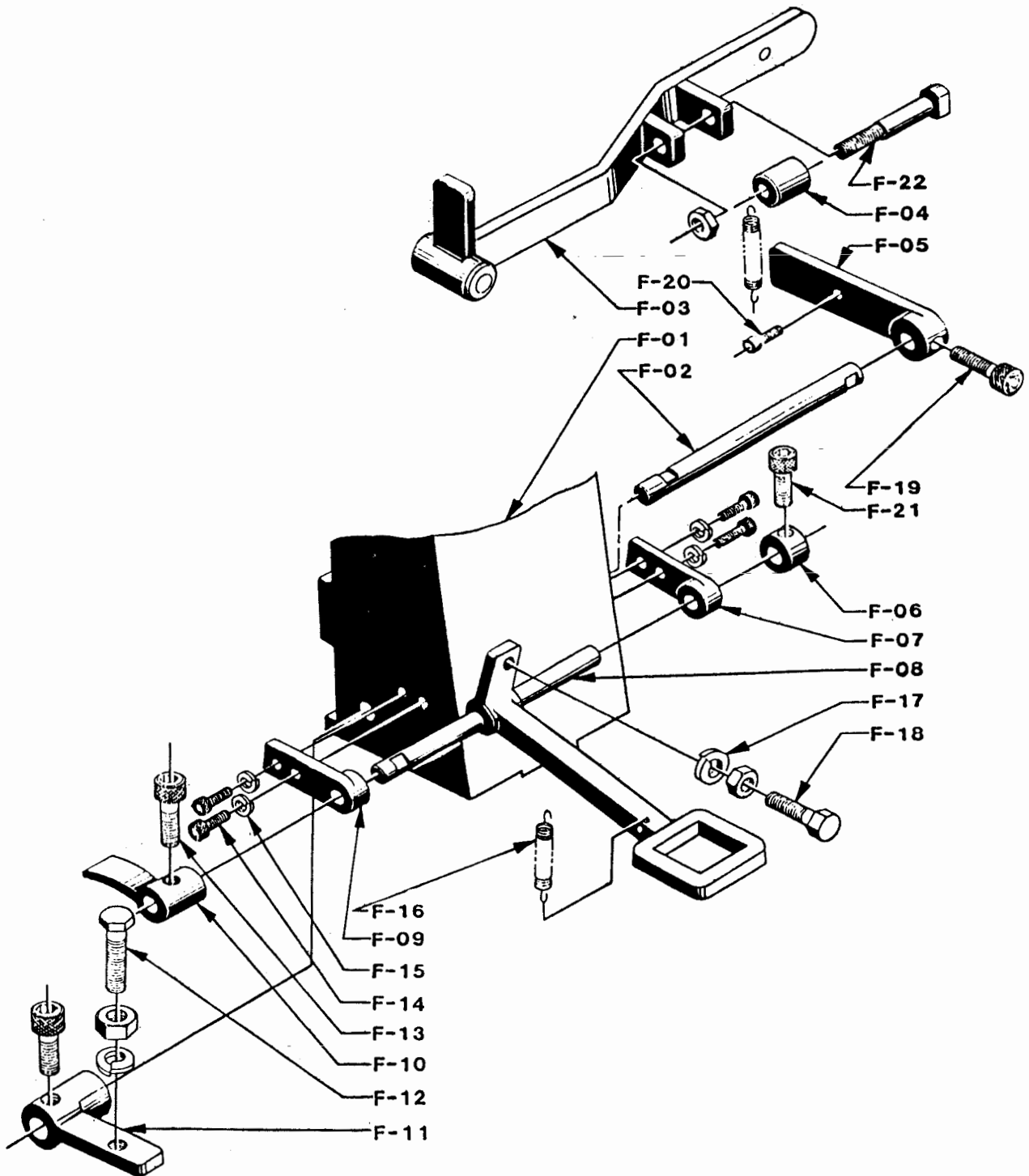

CLUTCH CONTROL SYSTEM EXPLODED VIEW

(FIG. 7)





圖7 零件表

件號 ITEM NO.	名稱 Description	數量 Qty	備註 Remarks
G-01	固定螺絲SCREW, CLUTCH LEVER HOOK	1	3/8"×1 1/4"ℓ
G-02	螺紋梢STOP PIN, CLUTCH LEVER	1	
G-03	離合器勾頭CLUTCH LEVER HOOK	1	
G-04	固定螺絲SCREW, STOP COLLAR	2	5/16"×1/2"ℓ
G-05	固定圓套STOP COLLAR	2	1"×1/2"×15'
G-06	勾簧板固定螺絲SCREW, HOOK PLATE	1	
G-07	勾彈簧板HOOK PLATE	1	
G-08	離合桿拉簧SPRING, CLUTCH LEVER	1	12°×77ℓ
G-09	彈簧拉斧頭螺絲SCREW, CLUTCH LEVER HOOK SPRING	1	3/8"×3/8"ℓ
G-10	斧頭CLUTCH LEVER	1	
G-11	斧頭拉桿臂(吊臂) TREADLE ROD ARM	1	
G-12	調位螺絲ADJUSTING SCREW, TREADLE ROD ARM	2	5/16"×1 1/4"ℓ
G-13	固定螺絲SCREW, BRACKET	2	5/16"×2 1/2"ℓ
G-14	支持架BRACKET, TREADLE ROD ARM	1	
G-15	二節心CLUTCH LEVER PIN	2	
G-16	固定螺絲SCREW, SUPPORT ROD	1	5/16"×1/2"ℓ
G-17	支撐螺桿SUPPORT ROD, BRACKET	1	
G-18	合鉤距離調整螺絲ADJUSTING SCREW, PINCH	2	3/8"×3"ℓ
G-19	後止TIE BAR, GUIDE BOARD	1	
G-20	固定螺絲SCREW, GUIDE BOARD TIE BAR	4	5/16"×1 1/4"ℓ
G-21	螺帽NUT, BRACKET SUPPORT ROD	1	3/8"
G-22	帶動下模滑道板GUIDE BOARD, SQUARE CONNECTING ROD	1	

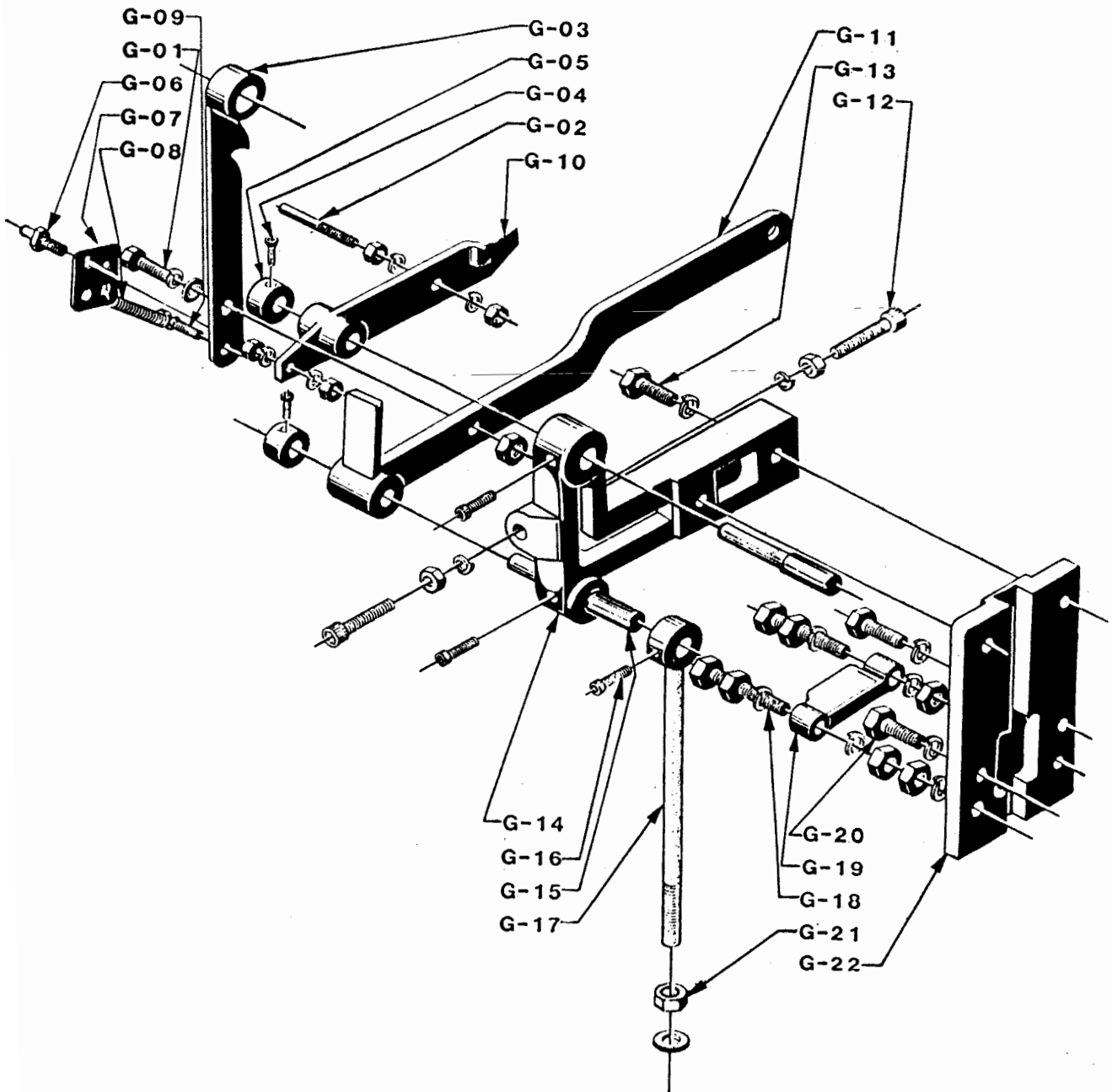

CLUTCH SYSTEM EXPLODED VIEW[OLD TYPE]

(FIG. 8)





圖8 零件表

件號 ITEM NO.	名稱 Description	數量 Qty	備註 Remarks
H-01	黃油杯GREASE CUP	1	
H-02	固定螺絲SCREW, OUTER COLLAR	1	5/16"×3/4"∅
H-03	固定環套OUTER COLLAR	1	1 1/2"×1"×16'
H-04	飛輪FLYWHEEL	1	
H-05	皮帶FLYWHEEL BELT	1	
H-06	飛輪離合卡梢INSERT, FLYWHEEL	2	
H-07	固定螺絲SCREW, CLUTCH CAM	2	3/8"×1"∅
H-08	離合器CLUTCH CAM	1	
H-09	控制凸輪CRANK	1	
H-10	離合梢CAM KEY, CLUTCH	1	
H-11	頂離合梢彈簧SPRING, CAM KEY	1	39∅×1.2°×4.8°×10
H-12	離合梢止擋片CAM KEY COVER	1	
H-13	固定螺絲SCREW	2	5/16"×3/4"
H-14	方形連桿頭滑輪TAPPET ROLLER, SQUARE ROD	1	1/2"×1"×16'
H-15	滑輪內襯套INNER BUSHING, TAPPET ROLLER	1	8°×1/2"×16.5'
H-16	滑輪支持螺絲PIN, TAPPER ROLLER	1	5/16"×2"
H-17	四角連桿SQUARE CONNECTING ROD	1	
H-18	螺絲THREADED PIN	1	5/16"×1 1/2"

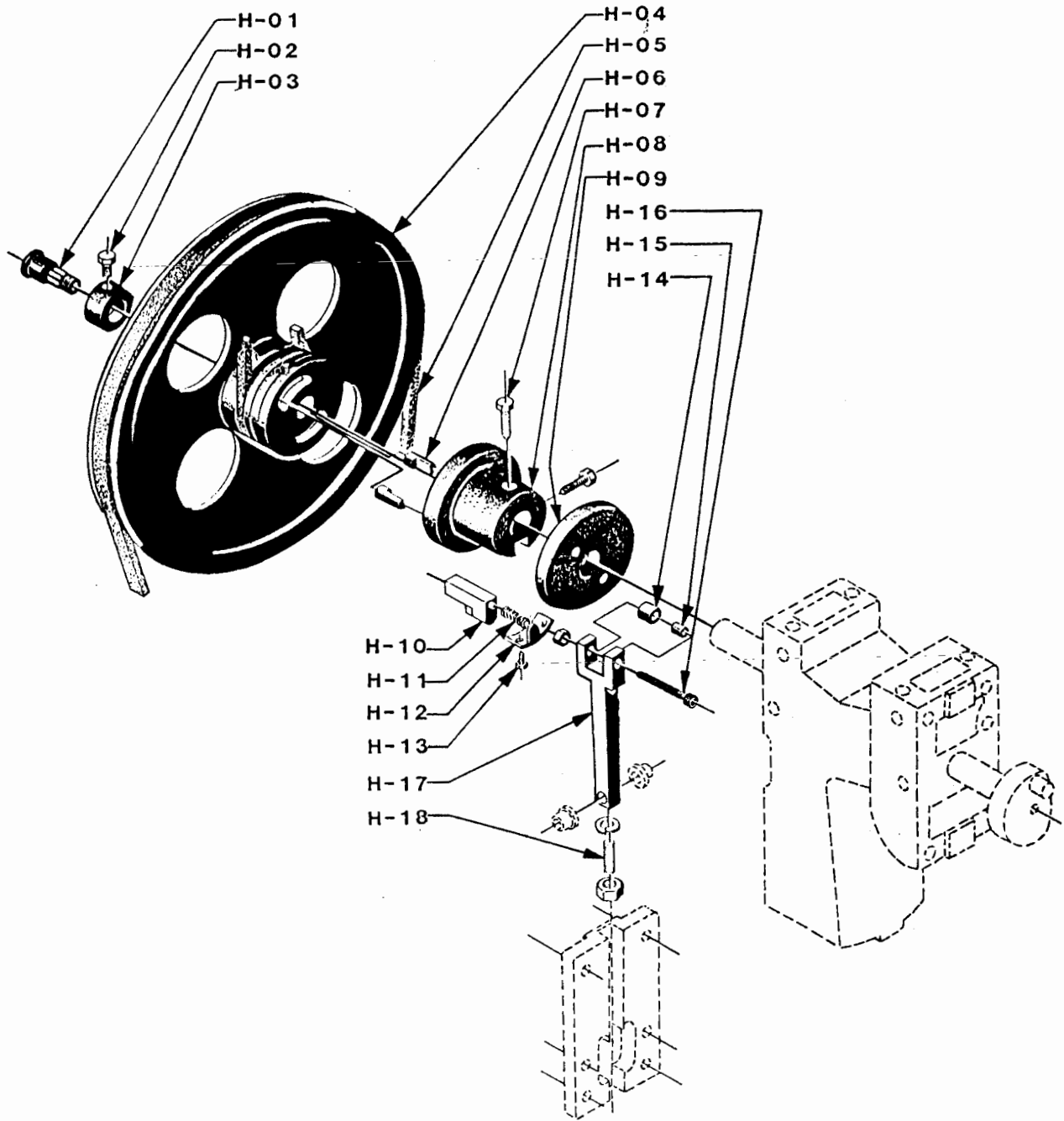

CLUTCH SYSTEM EXPLODED VIEW

[NEW TYPE] (FIG. 9)





圖9 零件表

件號 ITEM NO.	名稱 Description	數量 Qty	備註 Remarks
I-01	螺絲SCREW	2	
I-02	螺絲SCREW	3	
I-03	鋼珠護蓋COVER ROLLER	1	
I-04	反轉控制環STOP CLOCKWISE	1	
I-05	鋼珠ROLLER	1	1/4"×1/4"ℓ
I-06	固定螺絲SCREW	1	5/16"×3/4"ℓ
I-07	鋼套STEEL SLEEVE	1	
I-08	軸承BEARING	1	6007#
I-09	環墊RING	1	
I-10	飛輪皮帶FLYWHEEL BELT	1	A-74
I-11	大飛輪FLYWHEEL	1	
I-12	飛輪環FLYWHEEL RING	1	
I-13	定位梢FLYWHEEL, STEEL PIN	1	
I-14	飛輪內墊片DRIVE SHEEL THRUST-PLATE	1	
I-15	離合控制鋼珠CLUTCH ROLL	7	1/4"
I-16	七齒棘輪CLUTCH CAM	1	
I-17	離合器外殼CLUTCH CAGE	1	
I-18	彈簧SPRING	1	4°×66ℓ
I-19	阻擋片BACK STOP INSERT	1	
I-20	固定環CLUTCH COLLAR	1	
I-21	螺絲SCREW	1	3/8"×1 1/2"ℓ
I-22	剎車調整螺絲BRAKE ADJUSTING SCREW	1	5/16"×2 1/2"ℓ
I-23	剎車彈簧BRAKE SPRING	1	13.25°×2.3°×6.4°×39.4ℓ
I-24	剎車弓仔FRONT FRICTION BRAKE	1	
I-25	剎車皮FRICTION BRAKE FELT	2	
I-26	剎車弓仔FRONT FRICTION BRAKE	1	
I-27	剎車器BRAKE DRUM	1	
I-28	控制凸輪CAM	1	
I-29	主軸AXLE	1	
I-30	四角鍵KEY	1	1/4"×49ℓ
I-31	固定梢FIXED PIN	2	3/8"×30ℓ
I-32	固定梢FIXED PIN	1	5/16"×1 1/2"ℓ
I-33	固定梢SPRING PIN	1	
I-34	鋼墊片STEEL PIECE	1	
I-35	優力膠RUBBER SEAT	1	
I-36	支架RIGHT ANGLE PLATE	1	
I-37	固定梢SPRING PIN	1	
I-38	活動拉勾座CLUTCH LEVER	1	
I-39	離合器拉勾UPPER TREADLE ROD	1	
I-40	彈簧支柱LOWER STOP PIN	1	
I-41	彈簧SPRING	1	85.3ℓ×9°×1.8°×5.45°
I-42	固定螺柱SCREW SPINDLE	1	
I-43	固定螺絲SCREW	2	5/16"×1 1/4"ℓ
I-44	支架RIGHT ANGLE SEAT	1	
I-45	圓套SLEEVE	2	
I-46	支架L-SQUARE BAR	1	
I-47	固定螺絲SCREWS	2	
I-48	螺絲SCREW	1	
I-49	支撐柱POST SUPPORT	1	
I-50	螺絲SCREW	1	
I-51	支架固定板POST SUPPORT SEAT	1	
I-52	彈簧SPRING	1	

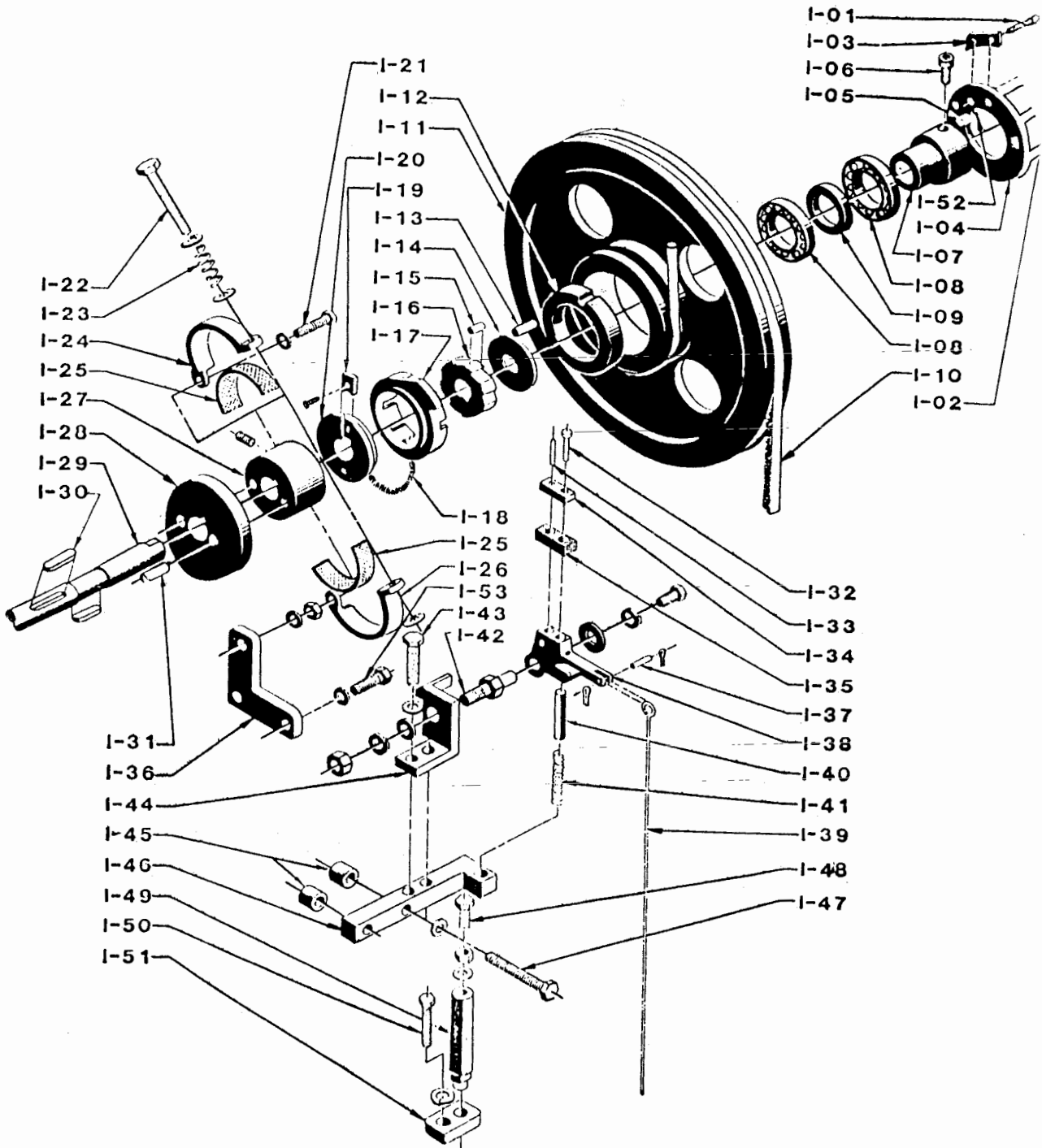

HEAD, COMPONENT CASE SYSTEM EXPLODE
VIEW (FIG. 10)





圖10 零件表

件號 ITEM NO.	名 稱 Description	數量 Qty	備 註 Remarks
J-01	拍動板固定螺絲SCREW	2	1/4"°×3/4"ℓ
J-02	拍動板PATTING CONTROL PLATE	1	
J-03	拍動頭PATTING CONTROL	1	
J-04	固定梢PIN	1	3/8"°×30ℓ
J-05	滑輪鋼心PIN	1	5.0°×16.5ℓ
J-06	滑輪PATTING CONTROL ROLLER	1	16°×5.1°×4.9'
J-07	四角銅仁SQUARE GUIDE BUSHING	1	
J-08	四角斗COMPONENT CASE	1	
J-09	頂流道螺絲 ADJUSTING SCREW	1	5/16"°×6.35ℓ
J-10	三節心銑仁MOVING GUINE, THREE-STEP-PIN	1	
J-11	固定銑仁螺絲SCREW.	2	5/16"°×3/4"ℓ
J-12	前蓋SIDE PLATE, COMPONENT CASE	1	
J-13	前蓋固定螺絲SCREW	2	3/16"°×3/8"ℓ
J-14	名牌貼紙NAME PLATE	1	
J-15	九 字 型 拉 鉤 9 - T Y P E H O O K	1	
J-16	彈簧SPRING, TRACK PLATE	1	60 × 7.7 ^D
J-17	螺絲SCREW	4	5/16"°×1 1/4"ℓ
J-18	三節心軸THREE-STEP-PIN	1	
J-19	上模固定彈絲FIXED SCREW.	1	5/16"°×1/2"ℓ
J-20	頂上模蕊彈簧COIL SPRING, DIE POST	1	1°×66 × 3.7 ^P × 20圈
J-21	上模組UPPER DIE	1	

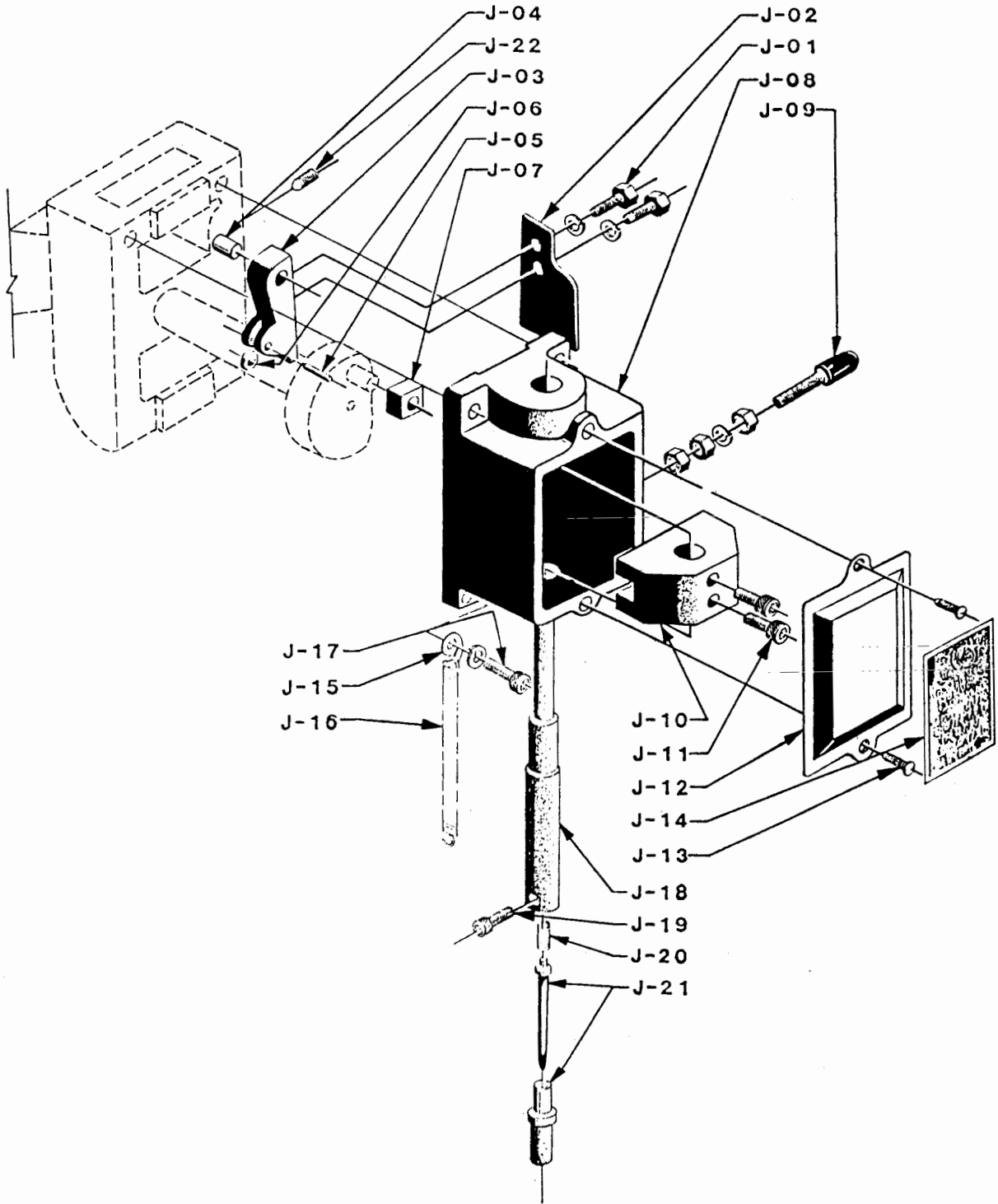

RIGHT FEEDING SYSTEM EXPLODED VIEW

(FIG. 11)





圖11 零件表

件號 ITEM NO.	名稱 Description	數量 Qty	備註 Remarks
K-01	皮帶輪PULLEY	1	
K-02	圓皮帶ROUND BELT	2	左右各一
K-03	固定螺絲SCREW	1	5/16"×3/4"ℓ
K-04	螺紋套固定螺母RING NUT, THREADED PIPE	2	
K-05	把手HANDLE KNOB	1	
K-06	螺絲SCREW		
K-07	清潔孔塞壓片CONNECTING PIECE, CLEANING PLUG	1	
K-08	墊環RING		
K-09	清潔孔塞CLEANING PLUG	1	
K-10	固定螺絲FIXED SCREW	1	5/16"×3/4"ℓ
K-11	四角板LOADING CHUTE PLATE	1	
K-12	漏斗入口HOPPER	1	
K-13	漏斗入口固定螺絲SCREWS	2	1/4"×3/4"ℓ
K-14	橡膠油封RUBBER SEAL		
K-15	彈簧鋼圈STEEL RING		
K-16	螺紋套THREADED PIPE, SPINDLE	1	
K-17	選料齒輪心軸SPINDLE (LONG)	1	
K-18	四角環HOPPER CONE RING SHIELD	1	
K-19	撥片STIRRERS	3	
K-20	撥片固定螺絲SCREWS, STIRRES	3	1/4"×3/8"ℓ
K-21	特殊墊片SPECIAL WASHER	1	
K-22	選料齒輪HOPPER CONE	1	
K-23	傳力圓套RING NUT SPINDLE	1	
K-24	彈簧COIL SPRING SPINDLE	1	4°×37ℓ×9°×5
K-25	壓花螺母RING NUT	1	
K-26	頂心板RIGHT EDGE SUPPORT	2	左右各一
K-27	頂心板固定螺絲FIXED SCREWS	4	1/4"×3/4"ℓ
K-28	固定螺絲FIXED SCREWS	2	1/4"×1"ℓ
K-29	頂心螺絲ADJUSTI OG SCREW, SUSPENSION BRACKET	2	
K-30	流道吊架SUSPENSION BRACKET, TRACK	1	
K-31	支架固定螺絲FIXED SCREWS BRACKET	2	3/8"×1"ℓ
K-32	四角板固定螺絲FIXED SCREWS	2	3/8"×1"ℓ
K-33	支架BRACKET, LOADING CHUTE PLATE	1	
K-34	流道固定螺絲SCREWS	2	1/4"×1"ℓ
K-35	流道組TRACK SET	1	
K-36	直角接片TRACK HOLDER PLATE	1	
K-37	螺帽NUT	2	
K-38	拍頭板調整螺絲PATTING PLATE ADJUSTING SCREW	1	3/8"×2"ℓ
K-39	流道拉簧TRACK SPRING	1	69.4ℓ×1°×7.7°
K-40	圓梢PIN	1	
K-41	控制頭EXIT CONTROLLER SHIELD	1	
K-42	控制勾拉簧EXIT CONTROLLER SPRING	1	
K-43	控制勾EXIT CONTROLLER	1	

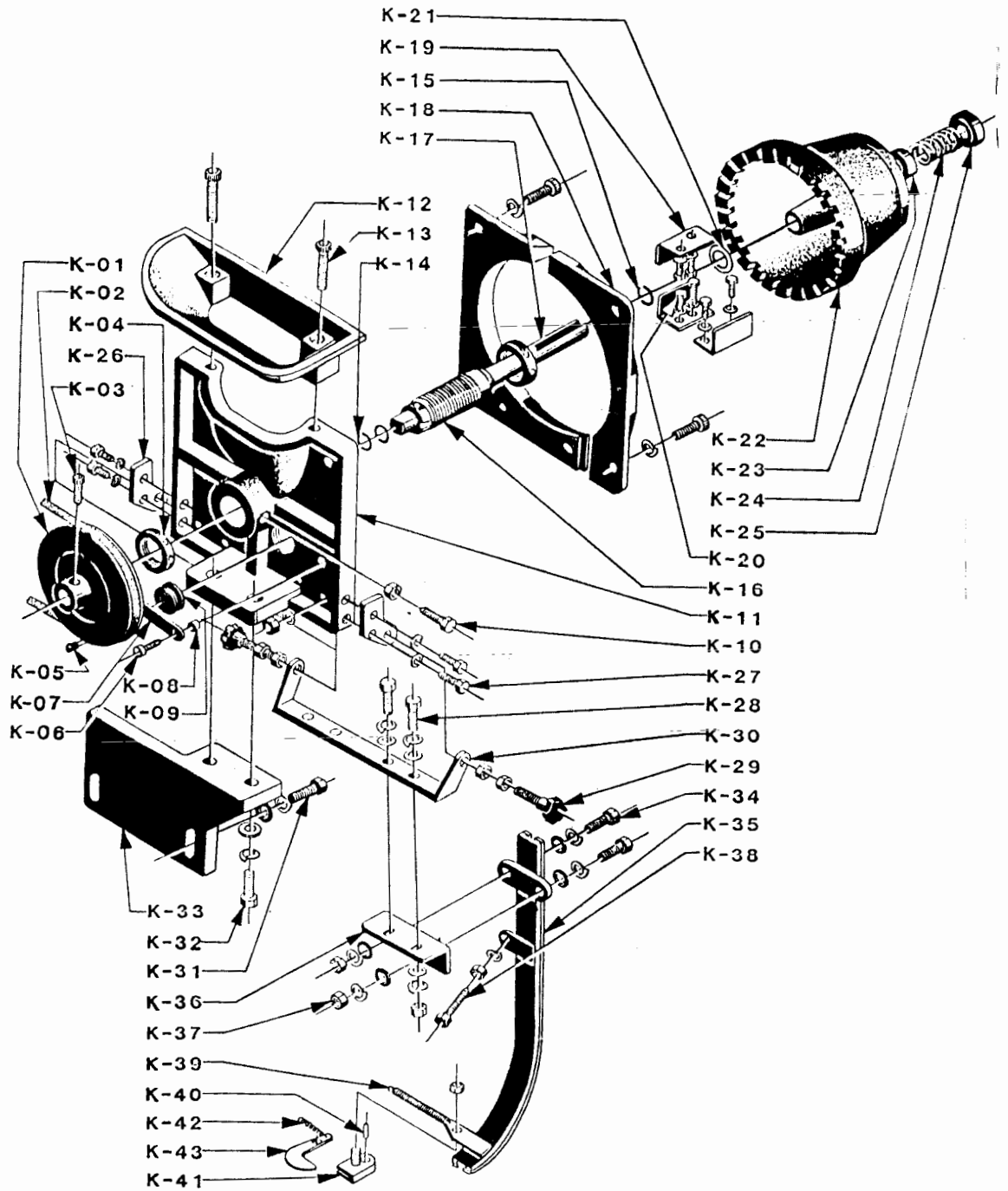

LEFT FEEDING SYSTEM EXPLODED VIEW

(FIG. 12)

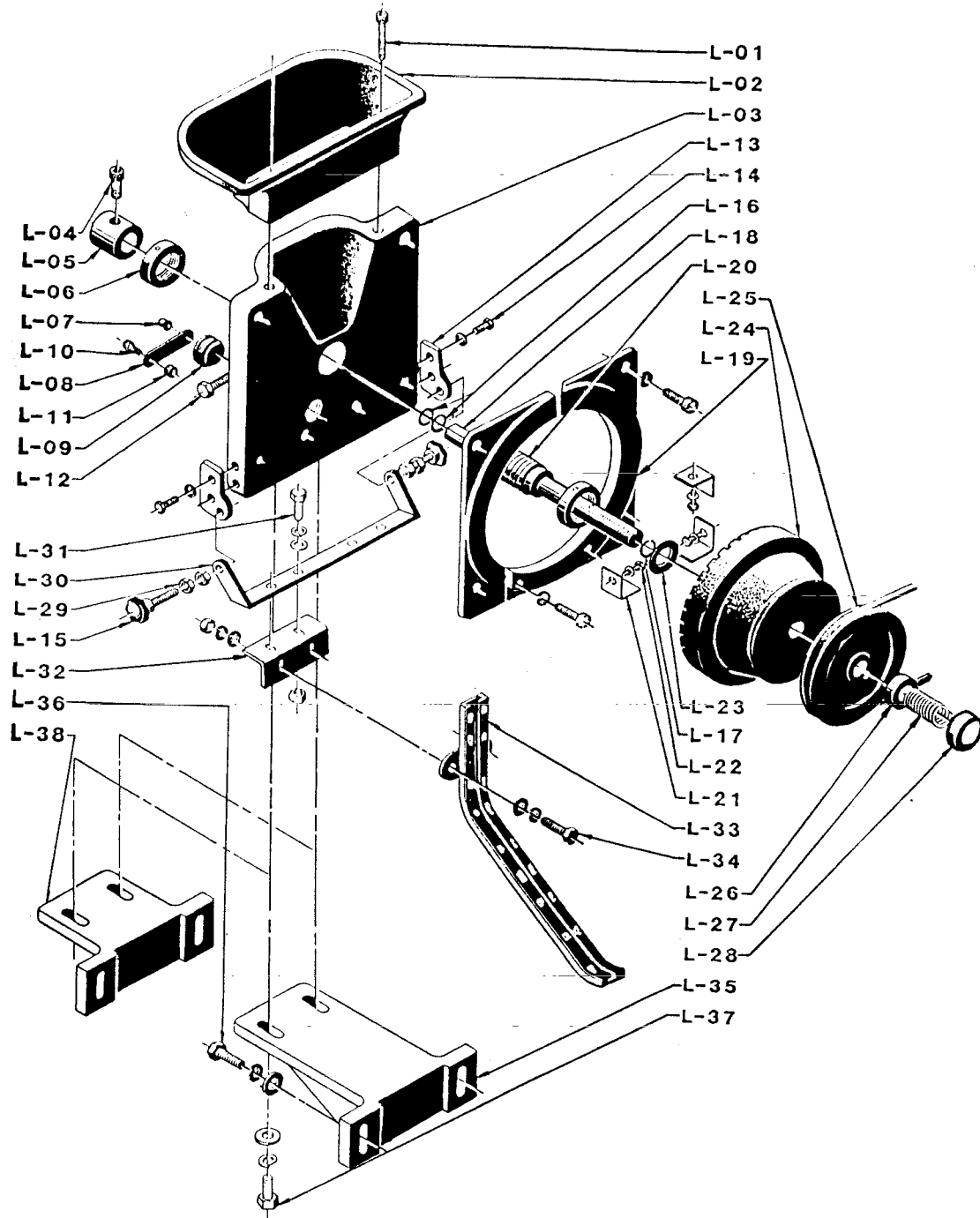

件號 ITEM NO.	名 稱 Description	數量 Qty	備 註 Remarks
L-01	漏斗入口固定螺絲 SOCKET CAP SCREW, HOPPER	2	1/4" × 1" <i>l</i>
L-02	漏斗入口 HOPPER	1	
L-03	四角板 LOADING CHUTE PLATE	1	
L-04	固定螺絲 FIXED SCREW	1	5/16" × 3/4" <i>l</i>
L-05	固定圓套 RETAINING SLEEVE, SPINDLE	1	1 1/4" × 5/8" × 30 <i>l</i>
L-06	螺紋套固定螺姆 RING NUT THREADED PIPE	2	
L-07	把手 HANDLE KNOB	1	
L-08	清潔孔塞壓片 CONNECTING PIECE, CLEANING PLUG	1	
L-09	清潔孔塞 CLEANING PLUG	1	
L-10	螺絲 SCREW	1	1/4" × 1 1/4" <i>l</i>
L-11	墊環 RING	1	3/8" × 7.0" × 15 <i>l</i>
L-12	固定螺絲 FIXED SCREW	1	5/16" × 1" <i>l</i>
L-13	頂心板 LEFT (RIGHT) EDGE SUPPORT	2	右左各一片
L-14	頂心板固定螺絲 SIDE SCREWS	4	1/4" × 3/4" <i>l</i>
L-15	頂心螺絲 ADJUSTING SCREW, SUSPENSION BRACKET	2	
L-16	橡膠油封 RING LOCK	2	
L-17	彈簧鋼圈 RUBBER SEAL	1	
L-18	選料齒輪心軸 SPINDLE (SHORT)	1	
L-19	四角環 HOPPER CONE RING SHIELD	1	較厚型 → 100019
L-20	螺紋套 THREADED PIPE, SPINDLE	1	
L-21	撥片 STIRRERS	3	
L-22	撥片固定螺絲 SCREW STIRRERS	3	1/4" × 3/8" <i>l</i>
L-23	特殊墊片 SPECIAL WASHER	1	
L-24	選料齒輪 HOPPER CONE	1	視鈕釦決定
L-25	皮帶輪 PULLEY	1	
L-26	傳力圓套 THREADED RING, SPINDLE	1	1 1/4" × 16" × 10 <i>l</i>
L-27	彈簧 COIL SPRING, SPINDLE	1	3.75" × 9" × 37 × 5圈
L-28	壓花螺姆 RING NUT SPINDLE	1	
L-29	螺帽 NUT	4	
L-30	流道吊架 SUSPENSION BRACKET	1	
L-31	固定螺絲 FIXED NUT	2	1/4" × 1"
L-32	直角接片 TRACK HOLDER PLATE	1	
L-33	流道組 TRACK SECTION	1	
L-34	流道固定螺絲 TRACK PLATE	2	1/4" × 1"
L-35	支架 BRACKET (LONG LOADING CHUTE PLATE)	1	
L-36	支架固定螺絲 FIXED SCREW BRACKET	2	3/8" × 1 1/4" <i>l</i>
L-37	四角板固定螺絲 FIXED SCREW, LOADING-CHUTE-PLATE	2	3/8" × 1 1/4" <i>l</i>
L-38	支架 SUPPORTER	1	與L-35任選一個



GROUP PARTS LIST



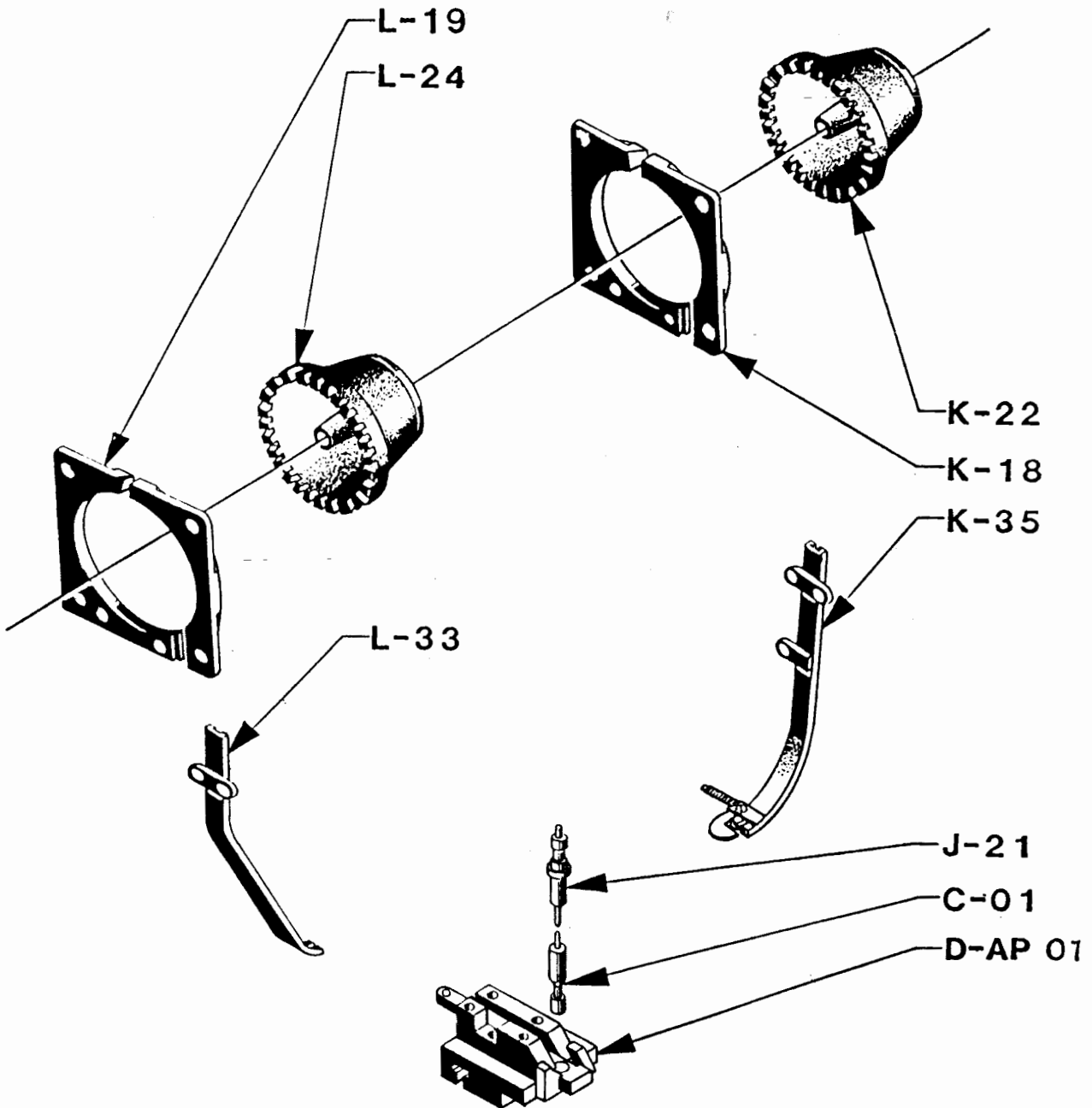



THE INDIVIDUAL GROUP PARTS OF HM-208A
ARE SUPPLIED WITH YOUR PURCHASE ORDER



總成及總成零件更換零件表

件號 ITEM NO.	名 稱 Description	數量 Qty	備 註 Remarks
C-01	下模DIE, LOWER	2	<p>ALL ITEMS OF THESE GROUP PARTS ARE REPLACEABLE BEFORE ORDERING YOU HAVE TO BE DEFINITE THE KIND AND SOME SUITABLE TO THE FASTENERS LIGNE ARE BEING USED MEANWHILE WE NEED YOUR BUTTONS ABOUT 200 PIECES FOR OUR MACHINE TRIALS.</p> <p>以上所有零件可以更換，在訂購之前你必須確認所使用的釦型及號碼，同時我們需要您寄上200個釦子以使機械試用。</p>
J-21	上模DIE, UPPER	2	
K-18	RING SHIELD SET (RIGHT)	1	
K-22	右選料齒輪HOPPER CONE SET (RIGHT)	1	
K-35	流道TRACK SET (RIGHT)	1	
L-19	四角環RING SHIELD SET (LEFT)	1	
L-24	左選料齒輪HOPPER CONE SET (LEFT)	1	
L-33	流道TRACK SET (LEFT)	1	
D-AP 01	推槽總成PUSHER SET	1	

正常損耗另件表
Normal Wornout Parts List

零 件 圖 Parts	件 號 Item NO.	數 量 Qty.	損耗(工/時) Worn out (W/Hr)	備 註 Remarks
	J-07	1	9000Hrs	<p style="text-align: center;">WITH CARE OF THE FLYWHEEL, CLUTCH AND SHAFT LUBRICATING PERFORMANCE IN REGULAR MAINTENANCE</p> <p>注意飛輪離合器之 定期保養</p>
	H-06	2	3000Hrs	
	H-10	1	3000Hrs	
	J-10	1	3000Hrs	
	G-10	1	3000Hrs	
	J-21	1		
	C-01	1		

WIRE DIAGRAM

